

## Dimensions - Imperial (ISO5211)

### Envelope Dimensions - Solenoid and Top Mounting Interface Sizes 25 - 600

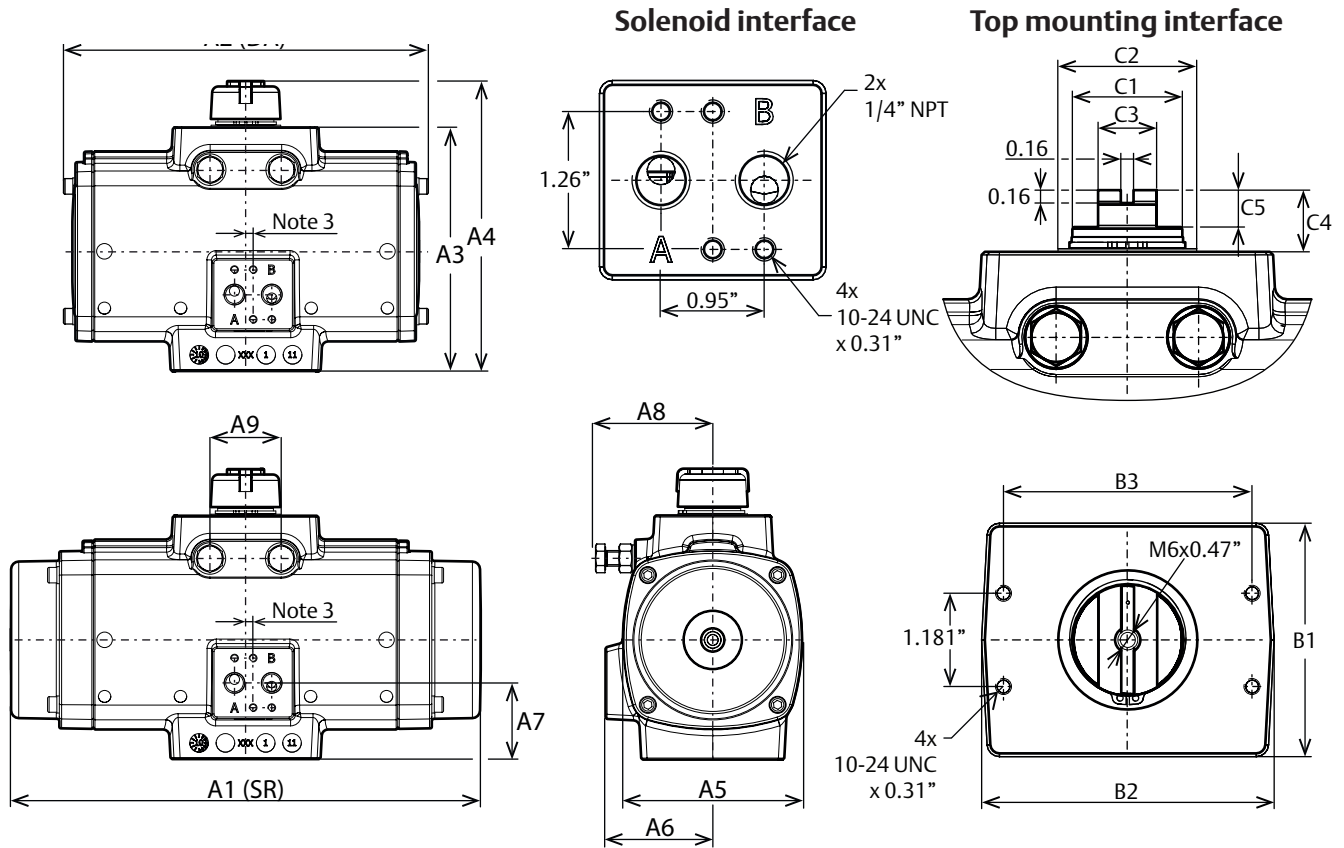

**Notes:**

1. DA = Double-Acting, SR = Spring-Return
2. Solenoid interface and top mounting interface according to VDI/VDE3845 (NAMUR)
3. The solenoid drilling pattern is shifted 0.16" for size 0025 and 0.08 mm for size 0040 vs the centerline of the actuator.
4. Imperial threads are UNC for fastener thread holes and NPT for air connection ports.

Dim in. Inches	Actuator size							
	0025	0040	0065	0100	0150	0200	0350	0600
A1	6.54	7.55	8.53	9.72	11.97	14.23	15.15	18.73
A2	6.54	7.55	8.53	9.72	9.25	10.43	11.18	14.02
A3	3.59	4.39	4.86	5.14	6.19	6.42	7.92	9.77
A4	4.69	5.47	5.94	6.22	7.28	7.52	9.06	11.50
A5	2.68	3.23	3.62	4.06	4.57	4.88	6.34	7.68
A6	1.91	2.15	2.28	2.50	2.72	2.83	3.35	4.02
A7	1.16	1.34	1.48	1.50	1.93	1.92	1.65	2.64
A8	1.89	2.28	2.72	2.72	2.95	3.43	4.29	5.20
A9	0.71	0.98	1.06	1.10	1.81	1.81	1.81	2.36
B1	1.69	1.77	1.97	2.36	2.95	2.95	3.35	3.86
B2	3.70	3.70	3.70	3.82	3.70	3.70	3.94	5.83
B3	3.15	3.15	3.15	3.15	3.15	3.15	3.15	5.12
C1	0.63	0.87	0.87	0.87	1.34	1.42	1.42	2.17
C2	0.91	1.18	1.18	1.38	1.77	1.77	1.77	2.56
C3	0.55	0.55	0.55	0.55	0.75	0.75	0.75	1.42
C4	0.79	0.79	0.79	0.79	0.79	0.79	0.79	1.18
C5	0.47	0.47	0.47	0.47	0.47	0.47	0.47	0.39

## Dimensions - Imperial (ISO5211)

### Envelope Dimensions - Solenoid and Top Mounting Interface Sizes 950 - 4000

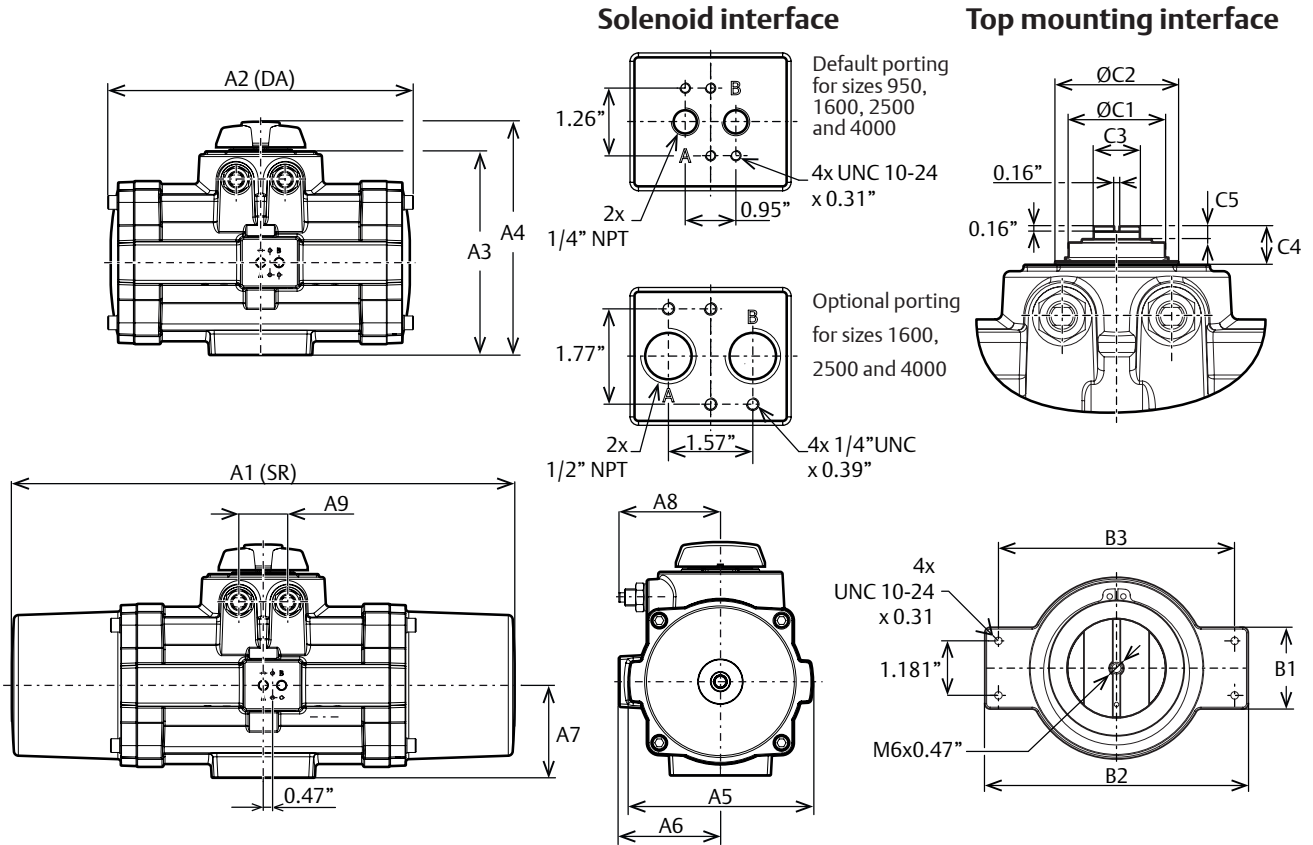

**Notes:**

1. DA = Double-Acting, SR = Spring-Return
2. Solenoid interface and top mounting interface according to VDI/VDE3845 (NAMUR)
3. The solenoid drilling pattern is shifted 0.95" for sizes 0950 to 4000 vs the centerline of the actuator.
4. The numbers in brackets are for actuators with 1/2" ports.
5. Imperial threads are UNC for fastener thread holes and NPT for air connection ports.

Dim in. Inches	Actuator size			
	0950	1600	2500	4000
A1	25.91	28.82	34.53	37.76
A2	15.75	18.19	21.65	25.55
A3	10.55	11.89	13.94	15.31
A4	12.01	13.35	15.43	16.81
A5	9.41	12.05	13.78	15.75
A6	5.16	5.87	6.69	7.72
A7	4.76	5.39 (5.51) <sup>4</sup>	6.18 (6.29) <sup>4</sup>	7.24 (7.32) <sup>4</sup>
A8	5.16	6.14	7.13	6.89
A9	2.52	3.35	4.02	7.24
B1	1.77	1.77	1.77	1.77
B2	5.71	5.71	5.71	5.71
B3	5.12	5.12	5.12	5.12
C1	2.56	2.95	3.74	3.78
C2	3.27	3.78	4.53	4.53
C3	1.42	1.42	1.42	1.42
C4	1.18	1.18	1.18	1.18
C5	0.39	0.39	0.39	0.39

## Dimensions - Imperial (ISO5211)

### Valve Flange and Drive Details Sizes 25 - 4000

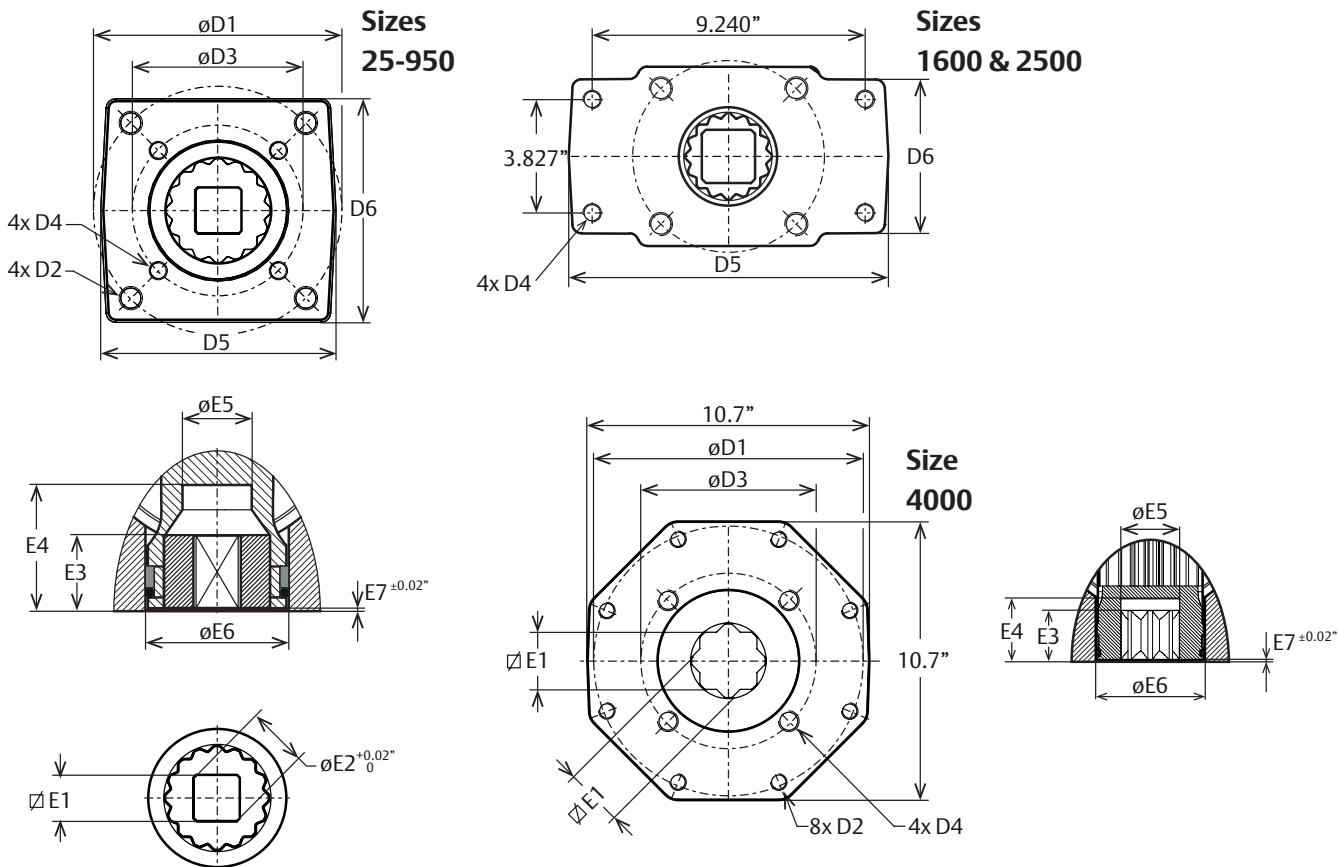

**Notes:**

1. Flange and square drive according to ISO 5211
2. F25\* = For sizes 1600 and 2500 drilling pattern 9.240"x 3.827" represent 4 holes of a F25 drilling pattern.
3. Size 4000 has 2x inner square E1 in the pinion bottom instead of inserts
4. Imperial threads are UNC for fastener thread holes and NPT for air connection ports.

Dim in. Inches	Actuator size											
	0025	0040	0065	0100	0150	0200	0350	0600	0950	1600	2500	4000
<b>ISO 1</b>	<b>F05</b>	<b>F07</b>	<b>F07</b>	<b>F07</b>	<b>F10</b>	<b>F10</b>	<b>F10</b>	<b>F12</b>	<b>F14</b>	<b>F16</b>	<b>F16</b>	<b>F25</b>
<b>D1</b>	1.969	2.756	2.756	2.756	4.016	4.016	4.016	4.921	5.512	6.496	6.496	10.000
<b>D2</b>	1/4"-20 x0.35	5/16"-18 x0.47	5/16"-18 x0.47	5/16"-18 x0.47	3/8"-16 x0.59	3/8"-16 x0.59	3/8"-16 x0.59	1/2"-13 x0.71	5/8"-11 x0.94	3/4"-10 x1.18	3/4"-10 x1.18	5/8"-11 x0.94
<b>ISO 2</b>	<b>F03</b>	<b>F05</b>	<b>F05</b>	<b>F05</b>	<b>F07</b>	<b>F07</b>	<b>F07</b>	<b>F10</b>	<b>F10</b>	<b>F25*</b>	<b>F25*</b>	<b>F16</b>
<b>D3</b>	1.417	1.969	1.969	1.969	2.756	2.756	2.756	4.016	4.016	-/-	-/-	6.496
<b>D4</b>	10-24 x0.31	1/4"-20 x0.35	1/4"-20 x0.35	1/4"-20 x0.35	5/16"-18 x0.47	5/16"-18 x0.47	5/16"-18 x0.47	3/8"-16 x0.59	3/8"-16 x0.59	5/8"-11 x0.94	5/8"-11 x0.94	3/4"-10 x1.18
<b>D5</b>	1.97	2.68	2.68	2.62	3.82	3.7	3.7	4.65	5.31	11.02	11.02	10.75
<b>D6</b>	1.89	2.56	2.56	2.48	3.62	3.54	3.7	4.45	5.12	5.2	5.2	10.59
<b>E1 Max.</b>	0.436	0.554	0.554	0.751	0.751	0.87	1.067	1.067	1.424	1.817	1.817	2.175
<b>E1 Min.</b>	0.433	0.551	0.551	0.748	0.748	0.866	1.063	1.063	1.417	1.811	1.811	2.165
<b>E2</b>	0.555	0.713	0.713	0.992	1.004	1.11	1.425	1.425	1.898	2.37	2.37	2.843
<b>E3</b>	0.591	0.591	0.591	0.709	1.083	1.083	1.083	1.083	1.909	2.343	2.343	2.421
<b>E4</b>	1.34	1.34	1.34	1.34	1.97	1.97	1.97	1.97	2.58	3.21	3.21	3.02
<b>E5</b>	0.56	0.71	0.83	0.93	1.12	1.26	1.26	1.44	1.89	2.36	2.36	2.87
<b>E6</b>	0.96	1.36	1.36	1.5	2.22	2.22	2.22	2.66	3.39	4.09	4.92	5.24
<b>E7</b>	0.02	0.04	0.04	0.04	0.05	0.05	0.05	0.05	0.04	0.04	0.04	0.04