

Drive Inserts

Key features

- Drive inserts allow actuators to be directly mounted to valves
- Eliminates the need for a bracket and coupling type mounting kit.
- The use of drive inserts significantly cuts the cost of the valve/actuator assembly.
- Standard actuators are fitted with square drive inserts
- Special inserts may have oversized or undersized squares, double-D and shaft key way forms.

Description

The EL-O-Matic F actuators are fitted with drive inserts. These drive inserts allow actuators to be directly mounted onto suitable valves in accordance with ISO 5211 and eliminates the need for a bracket and coupling type mounting kit. The use of direct mounts significantly cuts the cost of the valve/actuator assembly.

Standard actuators are fitted with square drive inserts in accordance with ISO 5211. The ISO 5211 standard covers parallel and diagonal oriented inner squares (as per old DIN 3337 standard).

Additionally, a wide variety of other inserts are also available. Special inserts may have oversized or undersized squares, double-D and shaft key way forms.

Drive inserts can be supplied on factory built actuators or as loose items and are easily replaceable at distributor or end user level.

Where direct mounts are not possible, for instance on valves with exposed gland packing, the use of inserts often simplifies the design of the mounting kit.

- Material: Aluminium alloy
- Finish : Anodized

Notes:

1. Actuator size F12 does not have inserts. This actuator size has the inner square directly in the bottom of the pinion.
2. Actuator size F4000 does not have inserts. This actuator size has two inner squares (diagonally and parallel oriented) directly in the bottom of the pinion.
3. Page 2 and 3 shows an overview of the default insert sizes and the most common square shaped insert sizes. Please contact your local EL-O-Matic representative for all available insert sizes.

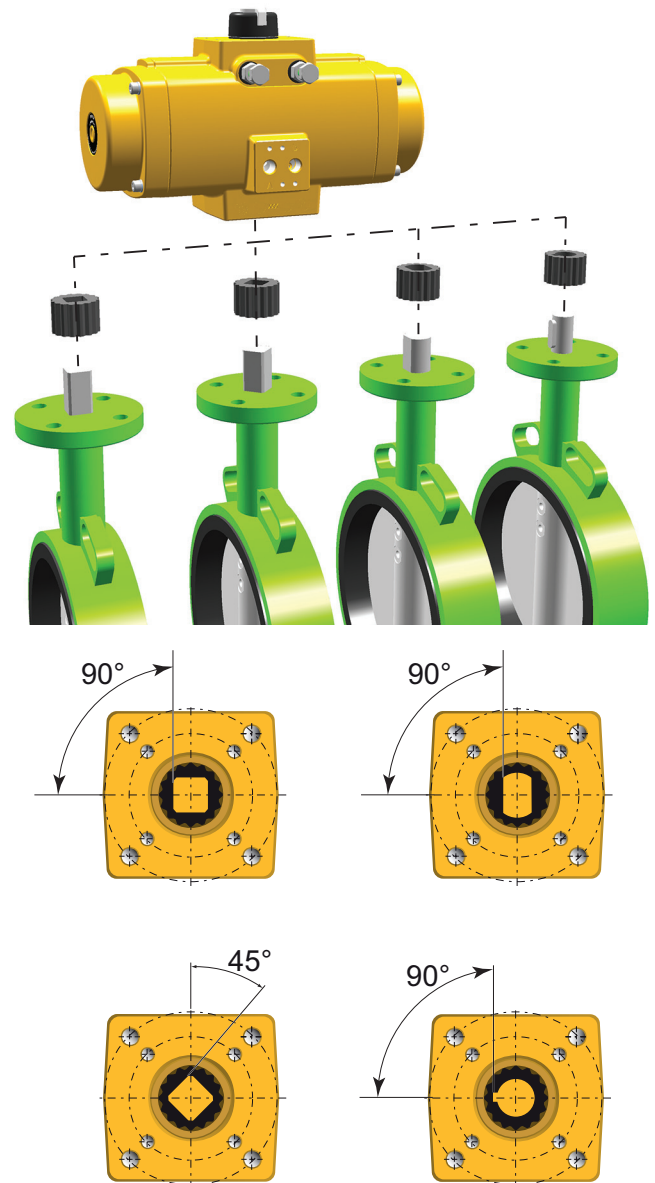

Table 1. Metric drive square overview

Dim. in mm	Inserts with inner-square-dimensions per actuator type											
	0012	0025	0040/ 0065	0100	0150	0200	0350	0600	0950	1600	2500	4000
Standard square drive dimensions												
Type	Square	Insert	Insert	Insert	Insert	Insert	Insert	Insert	Insert	Insert	Insert	Star drive
Parallel ■	9	11	14	19	19	22	27	27	36	46	46	55
Diagonal ◆	9	11	14	17	17	22	22	27	36	46	46	55
Optional square insert dimensions (Notes 1)												
No insert		8	8	9	9	9	9	9	14	22	22	No insert
		9	9	10	10	10	10	10	19	27	27	
		10	10	11	11	11	11	11	22	30	30	
			11	12	12	12	12	12	27	36	36	
			12	14	14	14	14	14	30			
			16	16	16	16	16	16				
					22	17	17	17				
					24	19	19	19				
					25	24	24	22				
				27	25	25	24					
					27		25					
Maximum adaptor/valve stem dimensions												
M1	No insert	34.5	34.5	34.5	50	50	50	52	64.5	81	81	No insert
M2		-	-	27.5	-	37	37	-	-	-	-	
P1		14.1	18.1/ 21.2	23.5	28.5	32.2	32.2	36.8	48.3	60.2	60.2	
P2		-	-	25.2	-	36.3	36.3	-	-	-	-	
Sq. max.		11	16	19	27	27	27	27	36	46	46	
D max.		13.8	21	23.6	33.6	33.6	33.6	33.6	45	60	60	

1. Above table shows an overview of the default insert sizes and the most common square shaped insert sizes. Please contact your local EL-O-Matic representative for all available insert sizes.

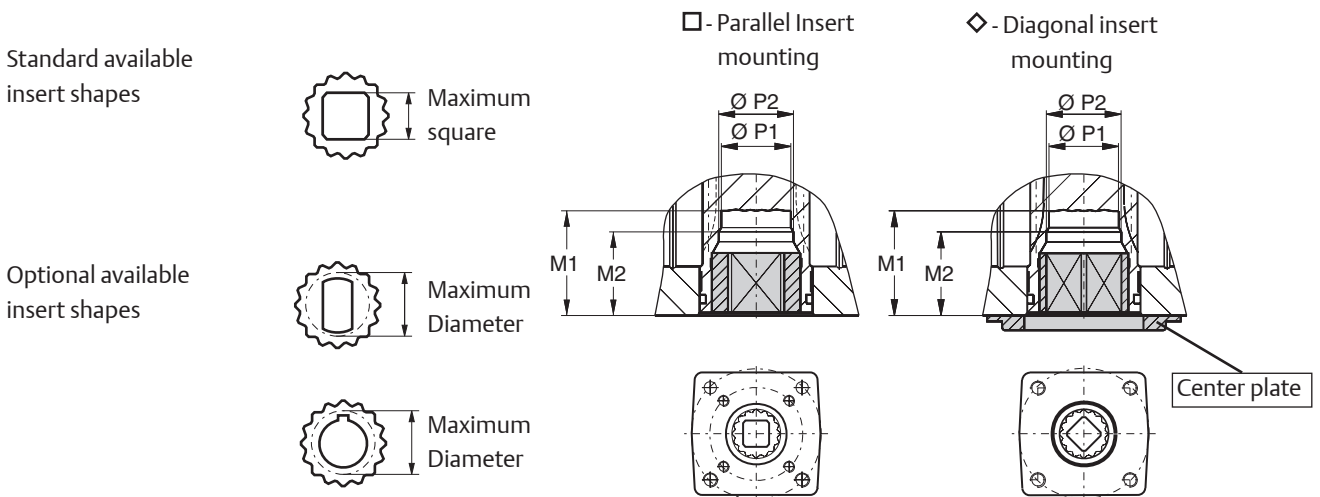
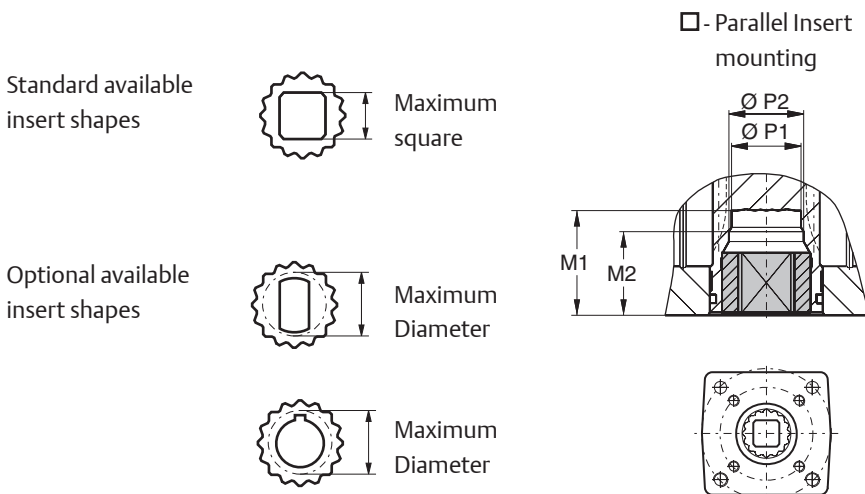

Table 2. Imperial drive square overview

Dim. in inches	Inserts with inner-square-dimensions per actuator type											
	12	25	0040/0065	100	150	200	350	600	950	1600	2500	4000
Standard square drive dimensions												
Type	Square	Insert	Insert	Insert	Insert	Insert	Insert	Insert	Insert	Insert	Insert	Star drive
Parallel ■	0.354	0.433	0.551	0.748	0.748	0.866	1.063	1.063	1.417	1.811	1.811	2.165
Diagonal ◆	0.354	0.433	0.551	0.669	0.669	0.866	0.866	1.063	1.417	1.811	1.811	2.165
Optional square insert dimensions (Notes 1)												
No insert		0.315	0.315	0.354	0.354	0.354	0.354	0.354	0.551	0.866	0.866	No insert
		0.354	0.354	0.394	0.394	0.394	0.394	0.394	0.748	1.063	1.063	
		0.394	0.394	0.433	0.433	0.433	0.433	0.433	0.866	1.181	1.181	
			0.433	0.472	0.472	0.472	0.472	0.472	1.063	1.417	1.417	
			0.472	0.551	0.551	0.551	0.551	0.551	1.181			
			0.630	0.630	0.630	0.630	0.630	0.630				
					0.866	0.669	0.669	0.669				
					0.945	0.748	0.748	0.748				
					0.984	0.945	0.945	0.866				
					1.063	0.984	0.984	0.945				
					1.063		0.984					
Maximum adaptor/valve stem dimensions												
M1	No insert	1.358	1.358	1.358	1.969	1.969	1.969	2.047	2.539	3.189	3.189	No insert
M2		-	-	27.5	-	37	37	-	-	-	-	
P1		0.555	0.717/0.835	0.925	1.122	1.268	1.268	1.449	1.902	2.37	2.37	
P2		-	-	0.992	-	1.429	1.429	-	-	-	-	
Sq. max.		0.433	0.630	0.748	1.063	1.063	1.063	1.063	1.417	1.811	1.811	
D max.		0.543	0.827	0.929	1.323	1.323	1.323	1.323	1.772	2.362	2.362	

1. Above table shows an overview of the default insert sizes and the most common square shaped insert sizes. Please contact your local EL-O-Matic representative for all available insert sizes.



Insert Removal tool

Description

The standard EL-O-Matic F-Series actuators are equipped with Square-Drive inserts according to ISO5211. When assembled at the factory, the inserts are press-fitted on an edge in the pinion bottom. In order to be able to replace these standard inserts, these insert removal tools will help you to easily remove the standard insert from the pinion bottom.

Availability

The insert removal tools are available in two versions and can be used up to actuator size 600. For larger actuator sizes, up to size 2500, it is recommended to use a generic pulley puller.

Intended use:

These insert removal tools are intended to be used just before the installation of the actuator onto a valve and where the default insert needs to be replaced by an insert with a different size or shape.

Operation:

The insert removal tools are equipped with 3 square bits that fit exactly in the insert square of the actuator. Make sure the square bits are as high as possible on the threaded rod. Then you can insert (1) and rotated 45° (2) the tool and one of the square bits will hook under the insert.

The knob (3) on the tool can now be rotated until the insert get loose (4) and it can be removed from the pinion's bottom.

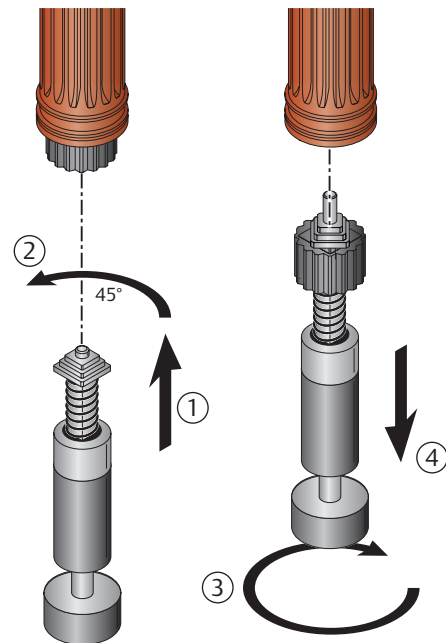

Specifications:

Tool part nr.:	Squares:	Actuator sizes:
VA590.00.001	11, 14 and 17	25, 40, 65, 100, 150
VA590.00.002	19, 22 and 27	100, 150 200, 350, 600

Materials:

Body, Knob and bits: Carbon steel, Zinc Plated