

Data sheet

Sheet No.: A3.402.3 Rev. B
Date: September 2017

EL-O-MATIC ACTUATOR WITH MANUAL OVERRIDE

MO-160

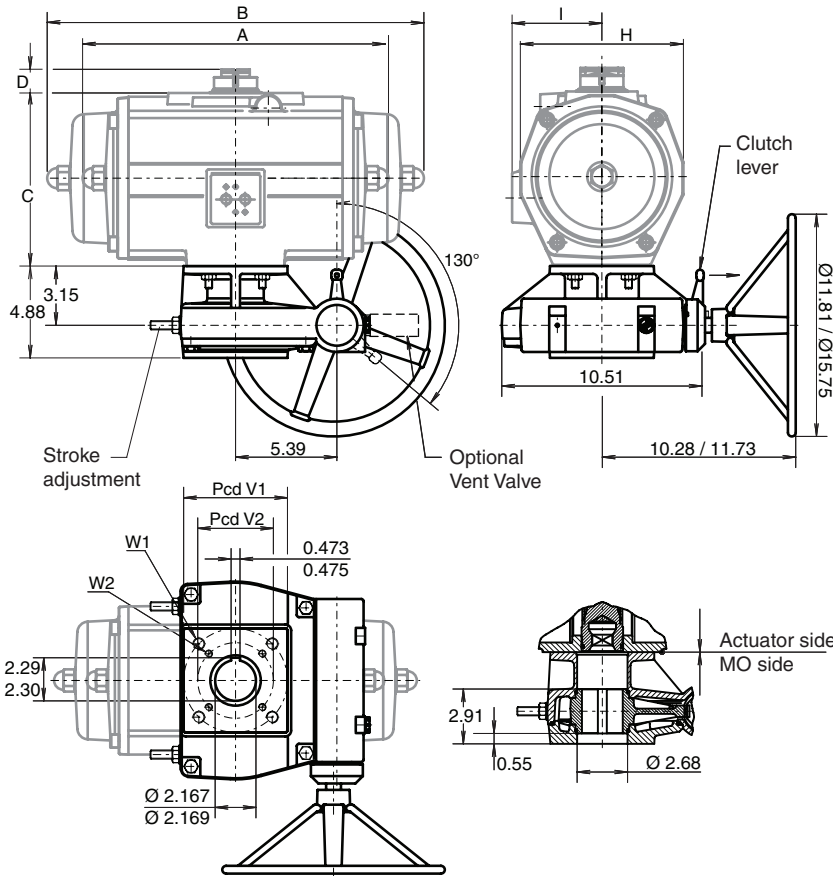

Description

The El-O-Matic MO Series declutchable gear operators offer simple and reliable manual positioning of valves, dampers and other quarter-turn devices when overriding, existing pneumatic or hydraulic rotary actuators. All El-O-Matic MO-units are suitable for indoor and outdoor use and combine rugged construction, light weight and modular design to provide the most efficient and cost effective solution to a full range of manual override requirements.

The self-locking worm gear design means safe and easy operation, positive manual positioning and extremely long life.

The El-O-Matic override can be adapted to any quarter-turn actuator and may even be installed in the field on existing valves.

Operation

To engage manual operation, first pull out the spring loaded clutch lever, then rotate the clutch lever clockwise until the clutch lever re-engages. Anticlockwise lever movement disengages manual operation and returns the system to automatic operation.

Note: When under manual control, the valve remains locked in the last set position.

Stroke adjustment

The MO gearbox is equipped with two stroke adjustment bolts. These must be set for accurate valve positioning and to avoid damage to the actuator or valve spindle during manual operation. The limit stops on actuators are redundant in combination with MO-gearboxes. For stroke angle less than 80° please consult our engineering department.

Identification

For basic override : MO-160 and indication of actuator size, e.g. : MO-160 for E350
For complete assemblies : P500+MO-160

Assembly codes

A - Standard
B - Reversed operation: handwheel on the other side (factory option)

Specification

Body	: Cast aluminum	Movement	: 0° - 90°
Gear quadrant	: Aluminum bronze	Finish	: Two part polyurethane coating
Worm shaft	: High grade aluminum / hard anodized	Weight	: 22.49 lb
Temperature	: -4°F to +176°F	Fasteners	: Stainless steel
Stroke adjustment	: +5° and -5° at each end		

Input / Output

At rim	No. of turns	: 20
	Max. input force	: 89.92 lb
At output shaft	Max. output torque	: 14161.3 in.lb

Optional

Electric position indication and vent valves (A3.403)

Dim. in inches	E350	E600	E950		E350	E600	E950
A (ED)	12.01	15.35	17.32	Pcd V1	5.512	4.921	5.512
B (ES)	15.24	18.90	20.94	Pcd V2	4.016	-	4.016
C	7.13	8.66	10.20	W1	5/8"-11 x.61	1/2"-13 x.59	5/8"-11 x.61
D	0.79	1.18	1.18	W2	3/8"-16 x.63	-	3/8"-16 x.63
H	6.81	8.15	9.09	Handwheel dia.	11.8	15.7	15.7
I	3.71	4.45	4.96				



EMERSON™