

Data sheet

Sheet No.: A3.402.4 Rev. B
Date: September 2017

EL-O-MATIC ACTUATOR WITH MANUAL OVERRIDE

MO-520/600

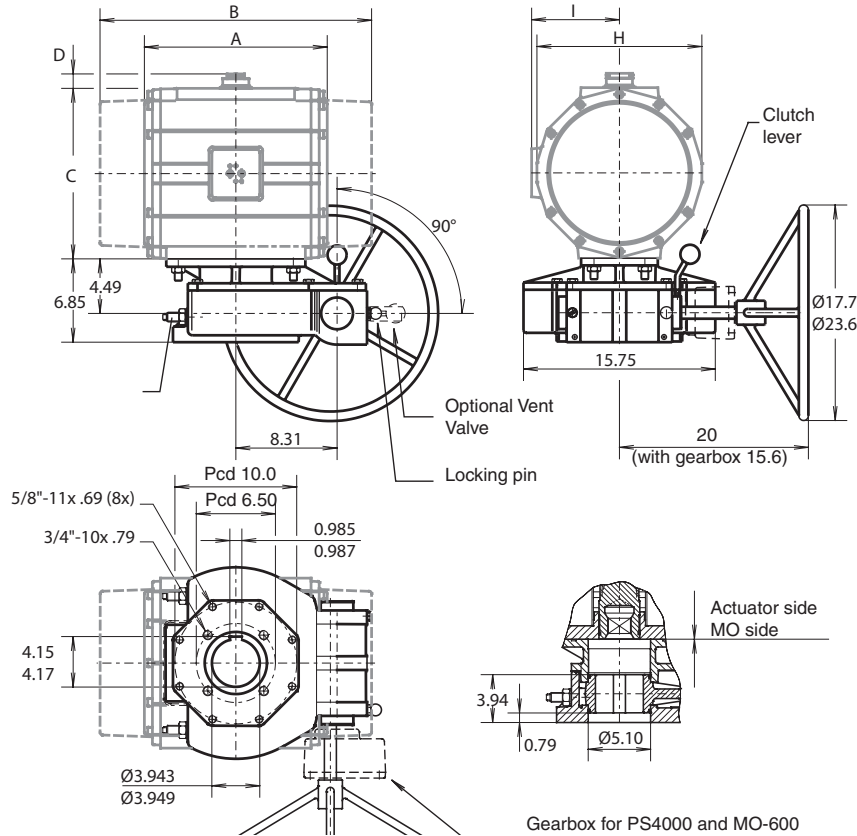

Dim. in inches	MO-520		MO-600	
	ED1600	PD2500	PD4000	PS4000
	ES1600	PS2500		
A ED	20.47	14.88	19.76	-
B ES	25.24	22.44	-	32.83
C	11.69	14.02	14.96	14.96
D	1.18	1.18	1.18	1.18
H	10.43	13.78	14.96	14.96
I	5.59	7.28	7.87	7.87
Handwheel dia.	17.7	17.7	23.6	17.7

Description

The EI-O-Matic MO Series declutchable gear operators offer simple and reliable manual positioning of valves, dampers and other quarter-turn devices when overriding, existing pneumatic or hydraulic rotary actuators. All EI-O-Matic MO-units are suitable for indoor and outdoor use and combine rugged construction, light weight and modular design to provide the most efficient and cost effective solution to a full range of manual override requirements.

The self-locking worm gear design means safe and easy operation, positive manual positioning and extremely long life. The EI-O-Matic override can be adapted to any quarter-turn actuator and may even be installed in the field on existing valves.

Operation

To engage manual operation, first pull the spring loaded locking pin, then rotate the clutch lever clockwise until the clutch lever re-engages. Anticlockwise lever movement disengages manual operation and returns the system to automatic operation.

Note: When under manual control, the valve remains locked in the last set position.

Stroke adjustment

The MO gearbox is equipped with two stroke adjustment bolts. These must be set for accurate valve positioning and to avoid damage to the actuator or valve spindle during manual operation. The limit stops on actuators are redundant in combination with MO-gearboxes. For stroke angle less than 80° please consult our engineering department.

Identification

For basic override : MO-520 and indication of actuator size, e.g.: MO-520 for P2500 or MO-600 for PE4000
For complete assemblies : P2500+MO-520 or PE4000+MO-600

Assembly codes

A - Standard
B - Reversed operation: handwheel on the other side (factory option)

Specification

Body	: Cast aluminum	Stroke adjustment	: +5° and -5° from each end
Drive sleeve / gear quadrant	: Cast iron / bronze	Movement	: 0° - 90°
Worm	: Steel	Finish	: Two part polyurethane coating
Shaft	: Stainless steel (AISI 430F)	Fasteners	: Stainless steel
Temperature	: -4°F to +176°F		

Input / Output

	MO-520	MO-600
At rim	No. of turns : 22	: 48
	Max. input force : 89.82 lb	: 40.47 lb
At output shaft	Max. output torque : 46024 in.lb	: 53104 in.lb
Weight	: 79.4 lb	: 83.8 lb

Optional

Electric position indication and vent valves (A 3.403)

