

## Fast Cycling F-Series actuators

### Increase the cycle speed of actuators

#### Cycle speed:

In general pneumatic EL-O-Matic F-series actuators are equipped with large internal air porting that allows adequate cycling under normal circumstances and when using generic solenoid valves to operate the actuator, the achieved cycle speed is normally sufficient.

In order to increase the cycle speed of the EL-O-Matic F-Series two options are available:

- High Flow plates
- Actuators with 1/2" air connection porting (only available for sizes F950 to F4000)

#### High Flow plates on Standard actuators

If faster cycle times are required (<0.5 or <1 second), 1/4" solenoid valves or pneumatic fitting material can become a problem. These components will then function as a throttle, reducing the potential maximum air flow and as such the limiting the maximum cycle speed.

In order to use the maximum cycle speed potential of a standard actuator, the 1/2" High Flow adaptor plate allows the fitting of larger solenoid valves and pneumatic fitting material and as such the increase the maximum cycle speed.

#### Construction:

The High Flow Plate is a aluminum plate which can be mounted directly to solenoid interface on actuators which are designed according VDI/VDE 3845 (NAMUR). The plate is supplied with fasteners and seals.

The customer side of the plate is equipped with one larger 1/2" NPT or BSP air connection (A-port) for piped solenoid control.

#### Materials:

- Block: Aluminium alloy, black anodized (10-15µm)
- Fasteners: Stainless steel
- O-ring seals: NBR Rubber

**Table 1. High Flow plates**

Part nr:	Execution:
VA306.00.310	1/2" NPT
VA306.00.320	1/2" BSP

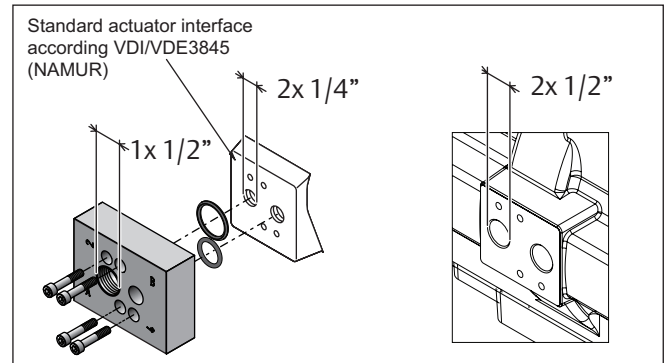

#### Actuators with 1/2" air connection porting.

In order to increase the cycle speed of actuator of the larger sizes F950 to F4000, these actuators are available with 1/2" BSP or NPT air connections for both the A and B port and comply with the 1/2" pneumatic connection specification of EN15714-3.

Additionally the internal air channels of the housing are larger than on the standard housing. Together with the mounting of 1/2" solenoid and or quick exhaust this allows very fast cycle speeds.

#### Maximum cycle speed

In order to select the correct actuator configuration, please find below a table of maximum cycle speeds that can be achieved for the standard 1/4" ported houses and the optional 1/2" ported houses.

1. For practical considerations follow the next recommendations.
2. Consult the nearest EL-O-Matic representative of Emerson office for technical support.

**Table 2. Maximum cycle speeds (seconds)**

Actuator size	House with 1/4" ports	House with 1/2" ports
12	0.4	Not available
25	0.4	Not available
40	0.5	Not available
65	0.6	Not available
100	0.7	Not available
150	0.8	Not available
200	1.0	Not available
350	1.5	Not available
600	2.2	Not available
950	2.5	0.8
1600	3.3	1.2
2500	5.4	1.7
4000	10.7	3.2

**Test conditions:**

Solenoid with flow capacity:

- Up to size 600	0.6 m <sup>3</sup> /hr	Not available
- 950 and larger	1.45 m <sup>3</sup> /hr	2.49 m <sup>3</sup> /hr

Pipe diameter:

- Up to size 600	6 mm	Not available
- 950 and larger	10 mm	12 mm

Medium:	Clean air	
Supply pressure:	5.5 bar/80psi	
Load:	With average load	
Stroke:	90°	
Temperature:	Room temperature	

**Notes:**

Faster stroking speeds are available but may require special design. If faster stroking speeds are required contact the engineering department.

**Recommendations:**

- The High Flow Plate or the 1/2" ported housing on its own do not make the cycle time of an actuator faster. Take care that there is sufficient air supply capacity at actuator:
  - Air supply capacity must be larger than the Cv or Kv value of the control solenoid valve.
  - Use tubing with sufficient large diameter.
  - Make tubing from the main air supply to the actuator as short as possible.
- Consider the use of Quick Exhaust valves in combination with High Flow Plate or the 1/2" ported housing.
- In general the actuators life cycle is reduced when cycling very fast.

**Table 3. Port dimension options F950 to F4000**

Dim	Metric Units		Imperial Units	
	1/4"	1/2"	1/4"	1/2"
S	1/4" BSP	1/2" BSP	1/4" NPT	1/2" NPT
S1	32	45	1.26"	1.77"
S2	24	40	0.94"	1.57"
S3	M5x8	M6x10	UNC 10-24 x 0.31"	1/4"UNC x 0.39"

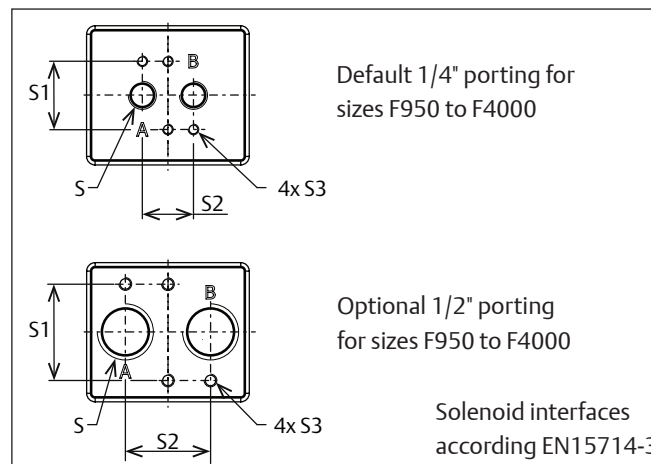

**Table 4. High Flow Plate Dimensions:**

Dimension in:	mm	Inch
A	63.5	2.50
B	82	3.23
C	25.4	1.00
D	32	1.26
E	25	0.98
F	16	0.63
G	29	1.14
H	12	0.47
J	27	1.06
K	1.27	0.05
L	1/2" BSP	1/2" NPT
M	1/4" BSP	1/4" NPT

